

# SCHÜCO



---

SCHÜCO AWS 75  
ALUMINUM WINDOW SYSTEM

# SCHÜCO AWS 75.SI+

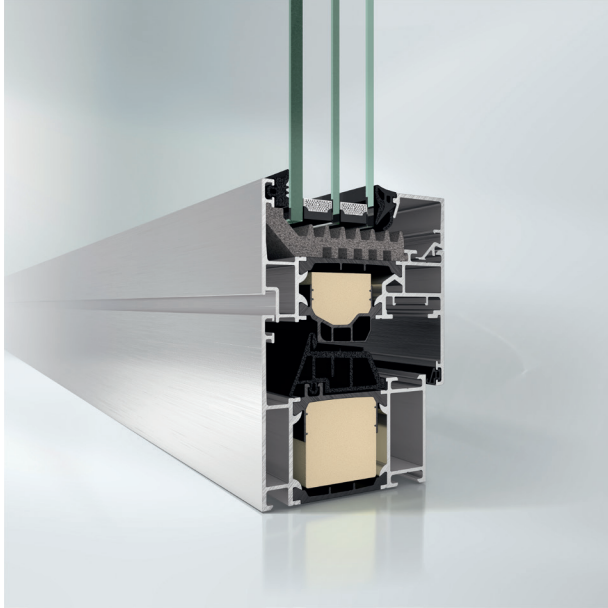

Schüco Window AWS 75.SI+, inward opening

In the basic depth of 2-15/16" (75 mm), the Schüco Aluminum Window System AWS 75.SI+ offers SI design (Super Insulation) which combines maximum thermal insulation with impressive properties in terms of function, design and fabrication.

With a continuous center gasket and a new glazing rebate insulation, the Schüco SimplySmart technology ensures more efficient fabrication. In combination with the Schüco AvanTec SimplySmart fittings, installation can be completed considerably faster.

As a block window with concealed vent frame, Schüco Window AWS 75 BS.HI+ fulfills the highest requirements in terms of architecture. The Schüco block system creates a particularly elegant window design without visible window vents. This attractive design option, where the outer frame completely covers the vent frame of the window, creates large transparent glazed areas due to its extremely narrow frame.



Schüco Window System AWS 75 BS.HI+, inward opening

## PRODUCT BENEFITS

- Attractive design options: Schüco Window AWS 75 BS.HI+ with concealed vent as block window with outstanding thermal insulation
- Continuous Schüco SimplySmart center gasket with optimized self-positioning, also available as block system option
- Simplified assembly processes reduce fabrication time
- Glazing rebate insulation as a molded piece: more efficient fabrication without time consuming manual working steps, reduction in assembly time
- Inward configurations: tilt/turn, turn/tilt, casement, hopper
- Outward configurations: casement, awning
- Crank operated turn/tilt solution option is available for large, heavy units

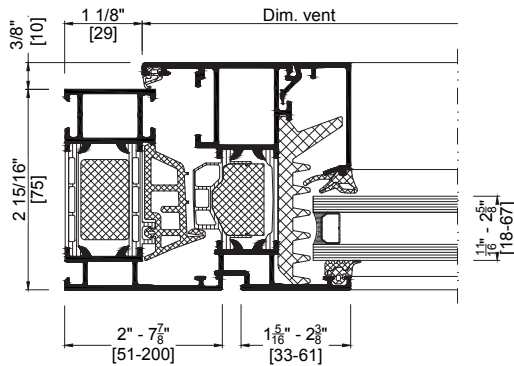

Schüco Window AWS 75.SI+, inward opening

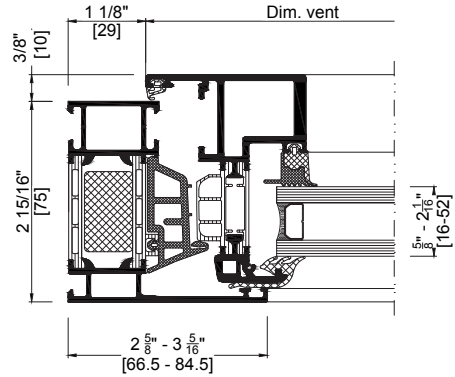

Schüco Window AWS 75.BS.HI+, inward opening

TECHNICAL DATA	AWS 75.SI+	AWS 75.BS.HI+																																				
Configurations	Side hung outward casement, awning	Turn-tilt, tilt-turn side hung casement, hopper																																				
Minimum Dimensions	Casement: 12-5/8" x 17-11/16" (320 mm x 450 mm) Awning: 17-11/16" x 17-11/16" (450 mm x 450 mm)	300 stay: 18-1/2" x 21-1/4" (470 mm x 540 mm) 400 stay: 22-7/16" x 30-11/16" (570 mm x 780 mm)																																				
Maximum Dimensions	Casement: 66-15/16" x 82-11/16" (1700 mm x 2100 mm) Awning: 86-5/8" x 78-3/4" (2200 mm x 2000 mm)	300 stay: 43-5/16" x 78-3/4" (1000 mm x 2200 mm) 400 stay: 59-1/16" x 78-3/4" (1500 mm x 2000 mm)																																				
Maximum Weight	Up to 287 lb (130 kg)	300 stay: up to 287 lb (130 kg) 400 stay: up to 353 lb (160 kg)																																				
AAMA Rating	AW-PG 65-75	AW-PG 70																																				
Water Tightness	15 psf (720 Pa)	15 psf (720 Pa)																																				
Hardware	Exposed barrel hinge, concealed hinge (projected)	Concealed, 180 ° opening possible																																				
Accessories	Code approved limiting restrictor, ADA handle option	Code approved limiting restrictor, continuous center gasket, ADA handle option																																				
Thermal Performance*	<table border="1"> <thead> <tr> <th>Glass U-Value</th> <th>Spacer Type</th> <th>Overall U-Value</th> </tr> </thead> <tbody> <tr> <td>0.29</td> <td>Aluminum</td> <td>0.38</td> </tr> <tr> <td>0.29</td> <td>TGI-M warm edge</td> <td>0.35</td> </tr> <tr> <td>0.24</td> <td>TGI-M warm edge</td> <td>0.33</td> </tr> <tr> <td>0.16</td> <td>TGI-M warm edge</td> <td>0.28</td> </tr> <tr> <td>0.10</td> <td>TGI-M warm edge</td> <td>0.25</td> </tr> </tbody> </table>	Glass U-Value	Spacer Type	Overall U-Value	0.29	Aluminum	0.38	0.29	TGI-M warm edge	0.35	0.24	TGI-M warm edge	0.33	0.16	TGI-M warm edge	0.28	0.10	TGI-M warm edge	0.25	<table border="1"> <thead> <tr> <th>Glass U-Value</th> <th>Spacer Type</th> <th>Overall U-Value</th> </tr> </thead> <tbody> <tr> <td>0.29</td> <td>Aluminum</td> <td>0.35</td> </tr> <tr> <td>0.29</td> <td>TGI-M warm edge</td> <td>0.33</td> </tr> <tr> <td>0.24</td> <td>TGI-M warm edge</td> <td>0.30</td> </tr> <tr> <td>0.16</td> <td>TGI-M warm edge</td> <td>0.23</td> </tr> <tr> <td>0.10</td> <td>TGI-M warm edge</td> <td>0.19</td> </tr> </tbody> </table>	Glass U-Value	Spacer Type	Overall U-Value	0.29	Aluminum	0.35	0.29	TGI-M warm edge	0.33	0.24	TGI-M warm edge	0.30	0.16	TGI-M warm edge	0.23	0.10	TGI-M warm edge	0.19
Glass U-Value	Spacer Type	Overall U-Value																																				
0.29	Aluminum	0.38																																				
0.29	TGI-M warm edge	0.35																																				
0.24	TGI-M warm edge	0.33																																				
0.16	TGI-M warm edge	0.28																																				
0.10	TGI-M warm edge	0.25																																				
Glass U-Value	Spacer Type	Overall U-Value																																				
0.29	Aluminum	0.35																																				
0.29	TGI-M warm edge	0.33																																				
0.24	TGI-M warm edge	0.30																																				
0.16	TGI-M warm edge	0.23																																				
0.10	TGI-M warm edge	0.19																																				
	*Information based on NFRC standard test size for side hung casement window (23-5/8" x 59" (600 mm x 1500 mm)). Units measured in Btu/hr-ft <sup>2</sup> -°F.	*Information based on NFRC standard test size for tilt turn window (47-1/4" x 59" (1200 mm x 1500 mm)). Units measured in Btu/hr-ft <sup>2</sup> -°F.																																				

Are you planning a building project using Schüco systems or would like to in the future? **Contact us.**

Schüco develops and sells system solutions for windows, sliding doors and facades. In addition to innovative products for residential and commercial buildings, the building envelope specialist offers consultation and digital solutions for all phases of a building project – from the conceptual idea through final design onto fabrication and installation. Machinery for fabrication and a 360° cycle of sustainability complement the range of products and services.

With more than 5,650 employees worldwide, Schüco strives to be the industry leader in terms of technology and service today and in the future. To this end, the company is always developing and testing new products and services for the entire building envelope, taking into account current market trends and standards. 12,000 architects, investors, developer, fabricators and glazing contractors around the world work together with Schüco. The company is active in more than 80 countries and achieved a turnover of 1.93 billion USD in 2020.

**Schüco USA LLLP**

240 Pane Road  
Newington, CT 06111  
Email: [info@schuco-usa.com](mailto:info@schuco-usa.com)  
Phone: +1 860.666.0505

